



相同企業有限公司

SIMILAR ENTERPRISE CO.,LTD

誠信第一、品質第一、服務第一

Sincerity & Honesty the first、
Quality the fir、stservice the first



塑膠污水陰井
Plastic Sewage Well

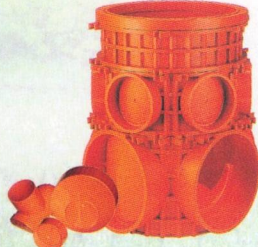

家庭污水配管箱
Kitchen Sewage Piping Box

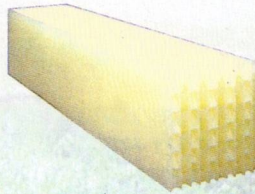

ABS材質傾斜管
Slanting Pipes



高傳氧散氣盤
High Oxygen Transfer
Disc Diffoser

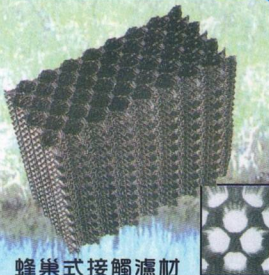

蜂巢式接觸濾材
Honeycombed Contact
Filter By PVC & ABS



HDPE材質網葉狀生物濾材
Network Shape Filter

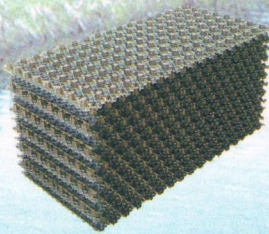

PVC/ABS材質高性能接觸濾材
Waved Crisscross Contact
Filter



PVC/ABS材質斜波浪接觸濾材
Waved Crisscross Contact
Filter



噴射渦流式粗氣泡散氣盤
Environmental Protection
Diffuser



生物旋轉盤(RBC)
Rotating Biological
Contactor(RBC)



MBR套裝系統
MBR Package System

專業的心  環保的情
是相同經營的理念



HISTORY

SAME CO., LTD.



公司簡介

近年來台灣地區在人口迅速增長及都市快速發展下，污水污染量亦隨之大量增加，居住環境品質亦隨之低落，水污染問題日益嚴重亟待解決。

相同企業於1995年成立之初，即以穩健經營、誠信敬業、精益求精之原則服務大眾，落實推動「誠信第一，品質第一、服務第一」的經營理念，並以完善的設計規劃及專業的施工技術服務，改善廢水處理品質而努力與堅持，希望在政府相關法規日益健全的配合下，污水處理設施能更普及，並大幅削減污水污染量讓我們生活的環境品質更美好。我們以專業服務及產品不斷創新改良與各大公、民營皆有配合且能深獲好評實績如下：澄清湖、豐原、龍潭、明德、新竹第二等淨水廠及中正機場、台化各廠、佳鼎科技、大統染廠、味全等。

現因經濟不景氣，同行業者以低價、劣品或偷工減料之產品搶奪市場的風聲常有所聞，競爭壓力日增。為求公司之永續經營，未來將以品質為後盾，並加強內部的控制與管理，以因應外在環境的變化及挑戰，強化公司體質，達成經營目標。

Recent years with the rapid growth of population and the fast development of cities in Taiwan district, the environmental inhabitant quality is lower and lower, and the water pollution is more and more serious which needs solution.

At the beginning of the establishment of Similar Enterprise Co., Ltd. In 1995, we serve the public with the principles of steady administration, sincerity and honesty, work-respecting, and pursuing for endless better performance, practicably propel the rational business concepts of "Sincerity & Honesty the First, Quality the First, and Service the First", and serve with the perfect design & schemes and professional constructive technologies to insist in striving to improve the disposal quality of the sewage. Through the co-operation of sounder and sounder relative rules of the government, we hope the sewage disposal equipment can be more widespread, and decrease the pollution volume of the sewage in large-scale to enable us to have a better living environment.

專業的心 環保的情
是相同經營的理念



「誠信第一，品質第一、服務第一」的經營理念

We continuously innovate and improve the technologies with professional service and products, cooperate with many major state-operated and private-owned projects, and have earned the appreciation of many people. The actual achievements are as follows: purification plants in the Cheng Ching Lake, Feng-yuan, Dragon Lake, Ming-te, the second purification plant in Hsin-chu, Chiang Kai-shek Airport, factories of Formosa Chemicals & Fibre Corporation, Vertex Precision Electronics Inc., Ta Tung Dye Factory, and Wei Chuan Corporation, etc.

Because of the unprosperity of the present time, it's often heard that industry owners of the same trade snatch the market with low price, minor products, or products of inferior materials. The competitive pressure is getting to increase day by day. For continuous operation of the company, we will take the quality as rear supporter, and strengthen the inner control and administration to cope with the changes and challenging of the external environment. Consolidating the physique of the company to live up to the business goals.

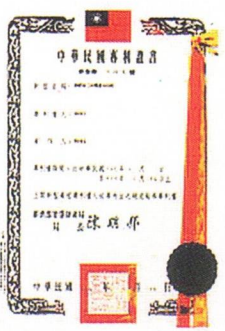



相同企業有限公司

SIMILAR ENTERPRISE CO.,LTD

傾斜管 SLANTING PIPES

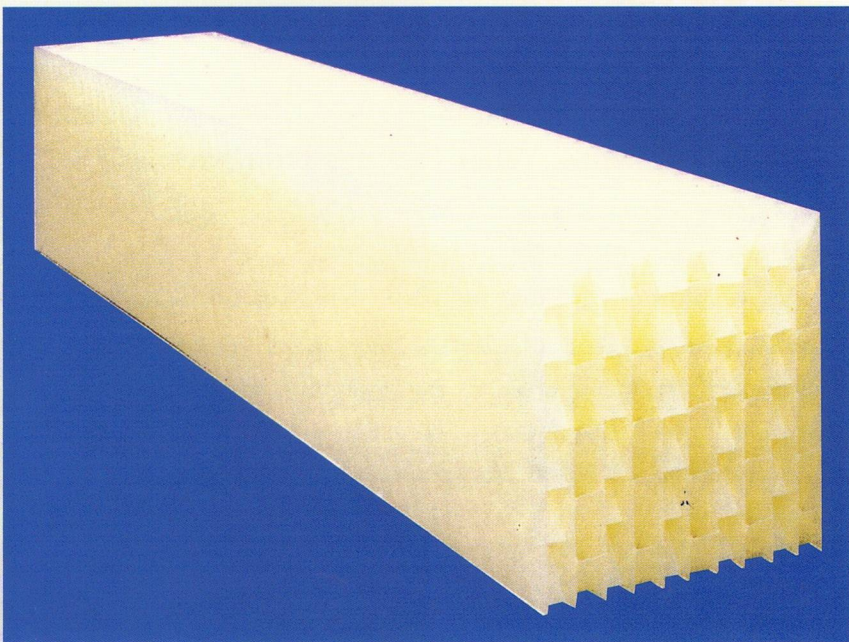

交叉複合式

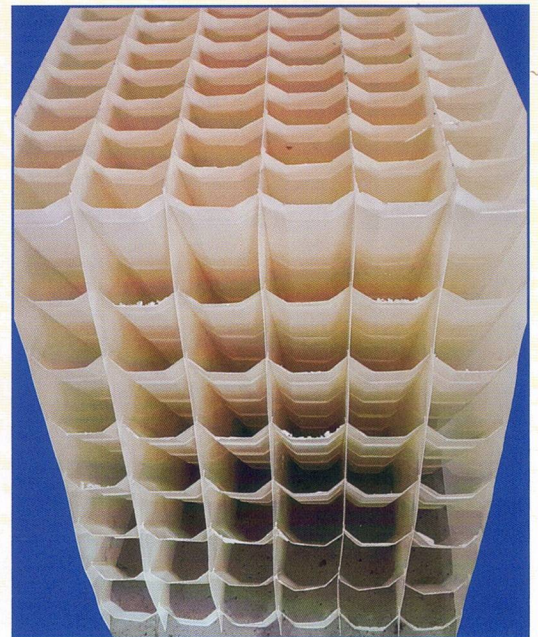

單斜式



池底 The bottom of pond

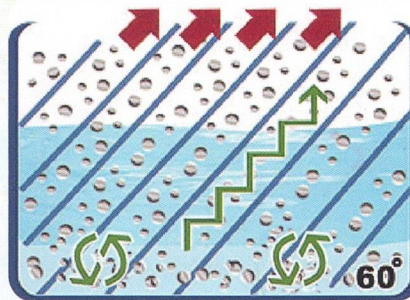

傾斜管 SLANTING PIPES

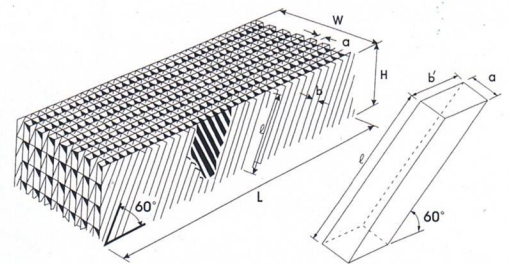

規格： SPECIFICATIONS:

單位mm

規格 Specification 型式 Model	管徑 Diameter of Pipes	A	B	E	W	H	L	管排 Pipes sets	板厚 Thickness of boards	材質 Materials
HCA-52	50	50	50	600	500	520	2500	10	0.6/0.8/1.0	ABS
HCA-75	50	50	50	860	500	750	2500	10	0.8/1.0	ABS

※尺寸可配合需求製作 Size as per request

整流作用

因為流路的細分，使原水的水流在管內成為層流，因此能得到接近理想的沉澱效果，普通一般以雷諾數表示水流狀態，雷諾數2,000以下時是屬層流，而傾斜管的雷諾數很低，通常流速是30~100。

Rectification

The ramification of water channel creates laminar flow within the pipe, thus results in a near-perfect sediment effect. Flow status is usually expressed in Reynolds number, with a value less than 2,000, indicating laminar flow. Generally, slanting pipe has a very low Reynolds number of 30~100.

特性

1. 優良的水質-水淨化

由於「整流作用」和「二次混凝效果」，能確實的捕捉不容易沉澱的膠羽，在各種沉澱設施之中經傾斜管處理過的水質可說是最優良的，並可節省混凝劑的消耗。

2. 強度高

雖然用厚度1mm以下的ABS板構造，因為是複合構架結構，所以重量既輕又強，並可承受500公斤以上的重量。

3. 安裝容易

安裝作業簡易，安裝時祇須放在支撐架上即可。

4. 維護方便

傾斜管模體僅有一層，構造上既無曲折且管壁光滑，因此維護非常方便。

5. 外觀優美

沒有吊樑架等障礙物，因此從沉澱表面視水質容易，而且外觀優美。

6. 可採用任收集污泥設施

因池底沒有障礙物，因此可自由的選擇收集污泥方向，收集污泥機，水中式刮泥機，輸送帶等任何收集污泥設施均可安裝，另傾斜管模體下面的空間很寬又大，因此檢查維護均非常容易。

7. 不受外來因素影響

在傾斜管內進行沉澱，因此不受密集流等外來因素的影響又傾斜管模體在水中因此沒有雪害。

8. 任何形狀的沉澱池均可裝置

橫流式沉澱池、圓型、方型沉澱池，任何形狀的沉澱池均可安裝。

FEATURES:

1. The "rectification" and "dual concrete effect" can truly catch the emulsion not easily precipitated.

The quality of water can be said to be excellent in a variety of precipitating facilities subject to the treatment in the slanting pipes. The consumption of concrete agent can be saved.

2. Although ABS structure at the thickness of 1mm is used. It should be strong and can bear a weight of over 500kg because of being a complex frame.

3. The installation is easy. Just put it on the frame at the time of installation.

4. There is only one layer of the slanting pipes. Structurally. There is no bending. So that it is very convenient.

5. There is no barrier such as girdle different from the slanting board so that it is easy to look at the quality of water from the surface of the precipitate pond. The appearance is good.

6. There is no barrier at the bottom of the pond so that you can freely choose direction for collection the mud, collecting mud machines, water mud excavating machines, and conveyance belts for installation. The space below the housing of the slanting pipes is wide and large so hat it is easy to check and maintain it.

7. Precipitation is conducted within slanting pipes so that it is no subject to the external factors such as dense current. The slanting pipes are in the water so that there is no barrier.

8. Horizontal precipitation pond figures, rectangular precipitation ponds, and precipitation ponds of any shape can be installed.

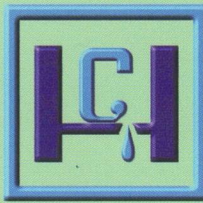

相同企業有限公司

SIMILAR ENTERPRISE CO.,LTD

斜坡浪生物膜接觸濾材

WAVED CRISSCROSS CONTACT FILTER

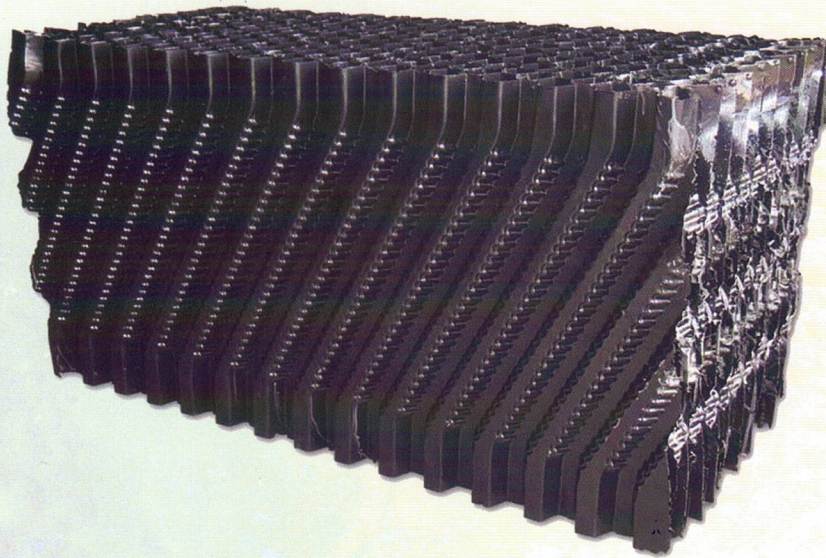

- ① 吸附期 period of adsorption
- ② 成長期 period of growth
- ③ 分裂繁殖 clastic reproducing
- ④ 自然呼吸期分裂繁殖 stationary phase
- ⑤ 脫落 peel

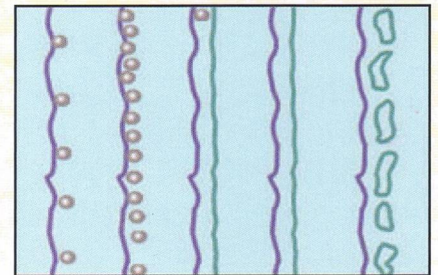

本接觸濾材為蜂巢式斜波浪交叉構造而成，採用耐酸鹼PVC材質，並經特殊霧面處理以利微生物寄生。

This contact filter is made with honeycombed crisscross structure. It is made of acid-proof and alkali-proof PVC material with foggy surface coating so that microbes are easy to be parasitic on.

規格 SPECIFICATIONS	尺寸(mm) Dimension	間隙(mm) Aperture	間隙率(%) Leaking rate	材質 Material	板厚(mm) Thickness	比表面積(m ² /m ³) Effective surface	座屈強度(kg/m ²) Strength
型式 Model HCM-60	LxHxW 1200x600x600	58	98.7	PVC	0.4~0.45	135	1500

其特性優點有：

- 一、比表面積大處理性能提高。
- 二、PVC材質、機械強度大、充填作業安全性佳，且不易斷裂、損壞、磨損，故使用壽命長。
- 三、濾材間隙大，故不易阻塞。
- 四、水的流通率良好。
- 五、浮游物捕捉性能極高。
- 六、接觸面設計兼顧生物泥膜附著性與剝落性。
- 七、安裝簡單，價廉物美。

FEATURES:

1. Larger surface with high treatment function.
2. PVC material used, great mechanical strength, can be installed with great safety. not easy to get broken or damaged, long consuming life.
3. Wide space between filters, not easy to get blocked.
4. Great water circulation rate.
5. High function rate of catching plankton.
6. The contact surface is designed with the functions for organisms to get cohered and to get flaked off.
7. Easy to be installed, low price with good quality.

本公司生物膜接觸濾材使用方法：

USAGE OF OUR WAVED CRISSCROSS CONTACT FILTER :

一、用於接觸曝氣法：

乃是將濾材浸於曝氣槽內之水中，並在槽內給予充分曝氣，使流入的廢水充分攪拌循環流動，而與濾材相接觸。經一段時間後，濾材表面開始生長附著生物性污泥（微生物）而形成生物膜，利用該生物膜在好氧性狀態下吸附及氧化廢水中有機物質的處理方法。

1. To be applied to contact gas explosion system:

To immerse the filters in gas explosion pond with sufficient gas supply to produce sufficient circulation for the flowing disposal sewage to touch the filters, after a period of time, the organic mud (microbes) will grow and be attached to the surface of filters and turn to be bio-membrane. Then the bio-membrane will absorb and oxidized the organic matter.

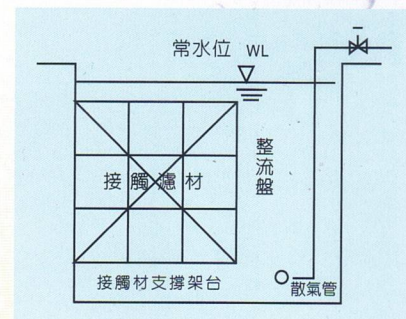

固定濾床

二、用於滴濾法：

只須把濾材架空於廢水池上，利用循環泵浦將廢水依週期性的分散均勻滴下，當廢水滴流通過此濾材一段時間後，濾材之表面形成一層膠狀的微生物膜，利用此生物膜，可達到吸收廢水中有機物質的處理功能。

2. To be applied to drop-filing system:

Prop the filing materials on the disposal sewage; use the circulation pump to drop down the disposal sewage has been dropping through the filing material for a period of time, there will be a colloid of bio-membrane on the surface of the filing material.

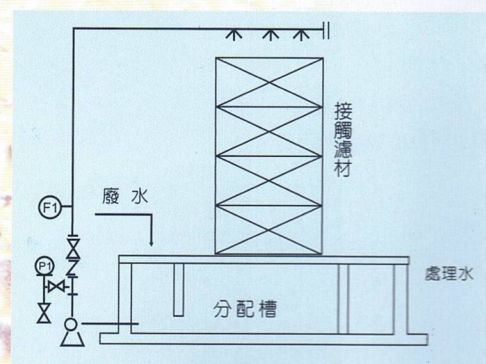

滴濾床

最適合處理對象：

- 一、下水及生活污水處理。
- 二、大小規模廢水處理。
- 三、三級處理。
- 四、低濃度廢水處理。
- 五、含難分解性質之廢水處理。
- 六、利用為不易形成膠羽或較輕膠羽之生物處理。
- 七、對於汙泥之處理，處分困難者不論其水質、水量，可適用本法產生污泥量少之特性處理之。

Applications :

1. Sanitary sewer and daily sewage treatment.
2. Disposal sewage with large or small quantity
3. Third grade treatment.
4. Low density of disposal sewage treatment.
5. Treatment for disposal sewage with substance that is difficult to be decomposed.
6. To treat plankton that are not easy to get colloid coating or that have light colloid coating.
7. This treatment is good for resolving the difficult parts of disposal mud like water quality and quantity, and can reduce the mud quantity.



相同企業有限公司

SIMILAR ENTERPRISE CO.,LTD

蜂巢式接觸濾材

Honeycombed Contact Filter By
PVC & ABS

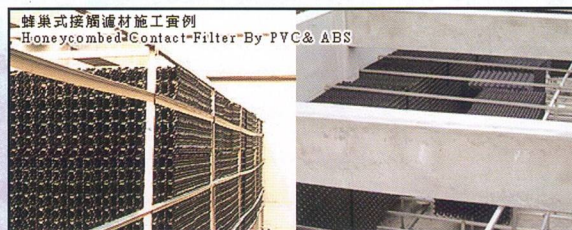
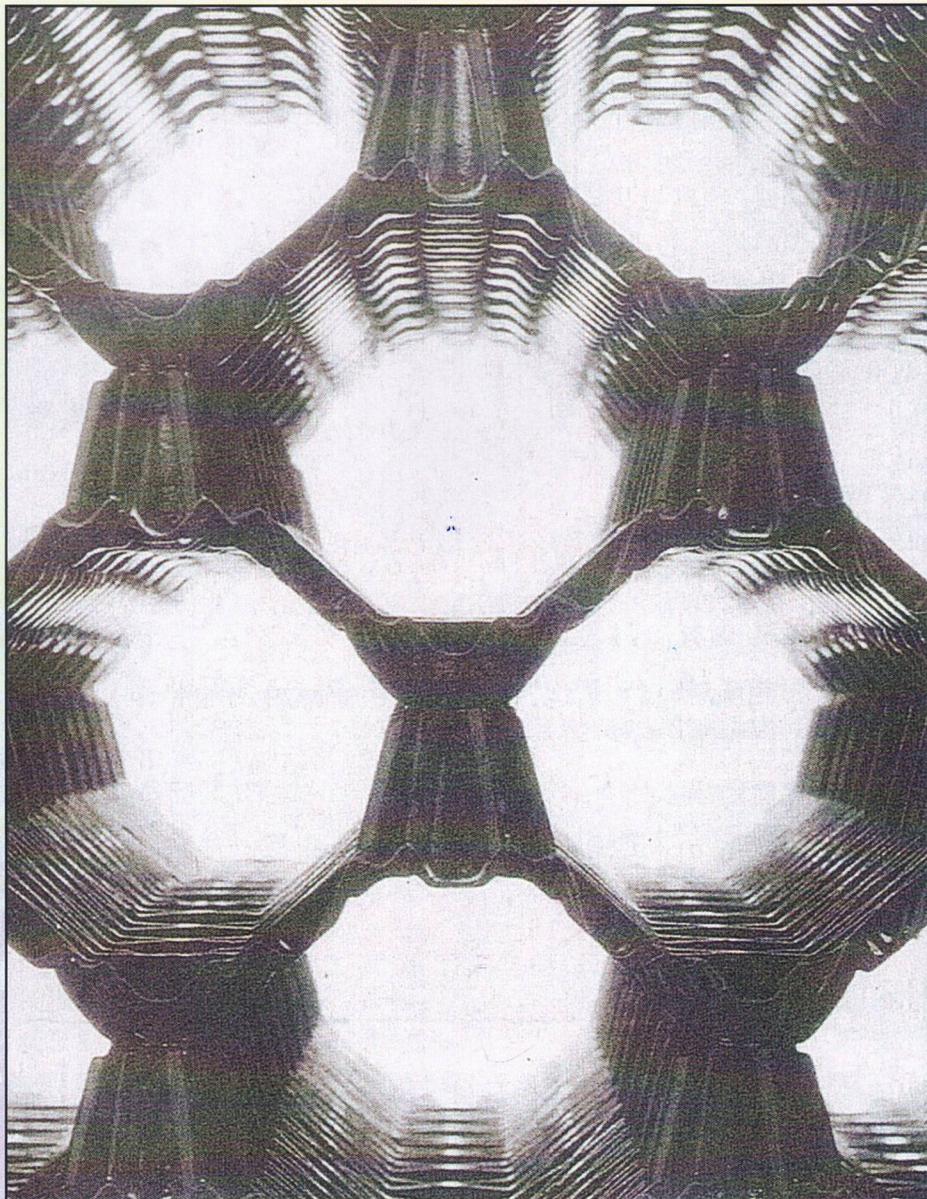

本接觸濾材為波浪狀開放接觸型之蜂巢式構造體，因而具有卓越的強度，承凹凸狀的表面，與流體之接觸面積廣而長，並使流體成亂流狀態，可達到接觸氧化之最高效率，是適用於所有有機廢水處理之劃時代產品。

This contact filter is made with waved open shape of honeycombed structure. It possesses outstanding strength that can bear the lumpy surface and contain a wide and long contact surface with flowing fluid, make it turn to turbulence condition and then reach the highest oxidize rate. This is the epochal product that is the best choice for applying to organic disposal sewage treatment.



特性和優點

- 一、比表面積大，處理能力優越(45-105m²/m³)。
- 二、強度卓越、作業安全性佳。
- 三、水阻小、空隙率大(99.0~99.3%)、接觸濾材不阻塞。
- 四、具適度之生物膜附著性。
- 五、浮游物的捕捉性高。
- 六、機械式的強度夠、不變形、不彎曲、耐久性佳。
- 七、費用低、效率高、具經濟效益。

FEATURES:

1. Larger surface with outstanding treatment function. (45-105m²/m³)
2. Remarkable strength and safe installation operation.
3. Little water resistance, high leaking rate(99.0~99.3%), no obstruct produced on contact filter.
4. Provided with moderate feature for bio-membrane to adhere to.
5. High feature for capturing plankton
6. Great mechanical strength, not easy to be out of shape, not easy to get curved, excellent durability.
7. Low expense, high efficiency, great economic benefits.

種類和規格

SPECIFICATIONS:

規格 Specification 型式 Model	間隙(m/m) Aperture	比表面積(m ² /m ³) Effective Surface Area	空隙率(%) Leaking rate	單片厚度(m/m) Thickness of single slice	標準尺寸 Standard dimension (m/m)		
					寬W	長L	高H
CM-80	80	53	99.2	0.55	1000	500	1000
CM-56	56	72	99.2	0.5	1000	500	1000
CM-40	40	105	99.0	0.4~0.5	1000	500	1000



相同企業有限公司

SIMILAR ENTERPRISE CO.,LTD

網葉狀濾材新型第126914號 減少佔地面積之高效能生物濾材 Network Shape Filter

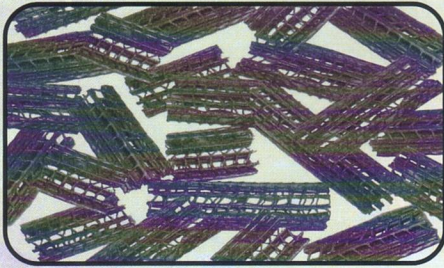
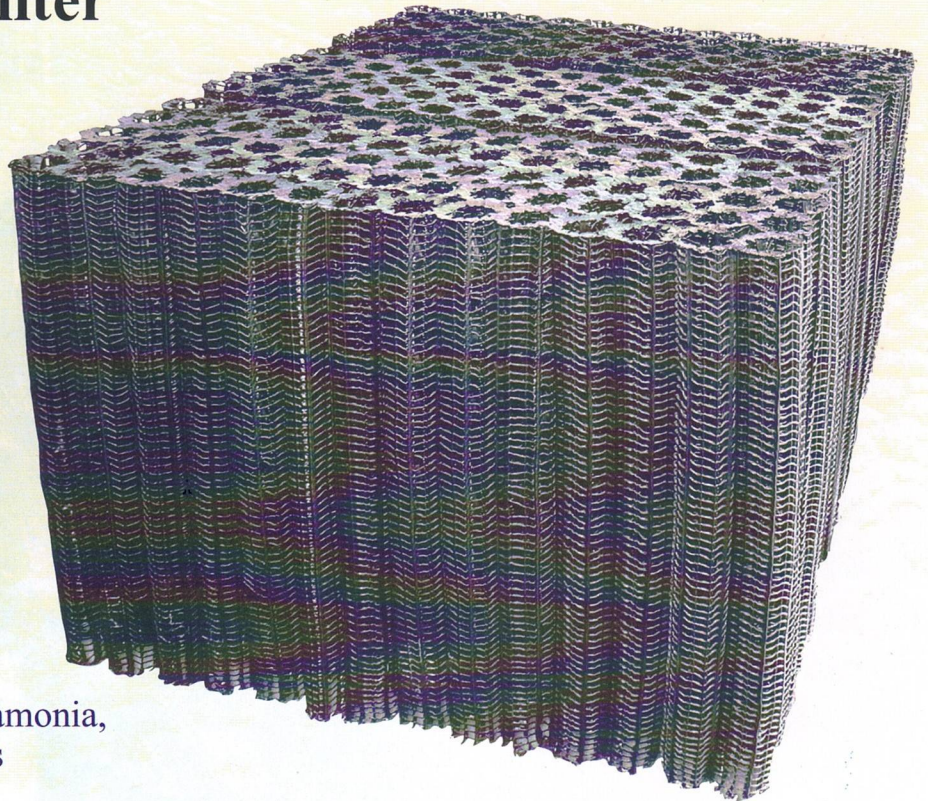

氨氮等有機祛除高手
(流動浮床)

High performance of handing amonia,
nitric and other organic matters

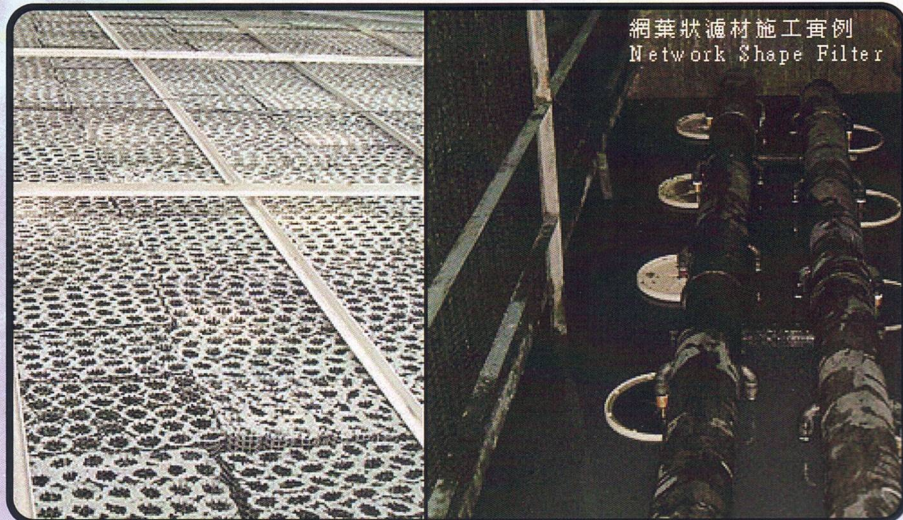

特性和優點

- 一. 採HDPE高密度環保材質。
- 二. 在非常短的時間即可形成生物膜，效率極高。
- 三. 有機物去除率高，減少佔地面積，整體投資成本低。
- 四. 機械強度大，每 m^2 座屈強度8噸以上。
- 五. 粗糙的表面易使生物附著。
- 六. 網葉狀通透性佳是有效作用無阻礙的高效能生物接觸濾材。
- 七. 使用壽命長。
- 八. 保養費用少。
- 九. 可任意型態（如：流動浮床式.滴濾式.浸漬式皆可）且可任意長度。

FEATURES:

1. Made of HDPE high-density environmental protection
2. Form bio-membrane within a very short period with high efficiency
3. High rate of removing organic substances, reducing the area occupied. Low investment costs.
4. Great mechanical strength with the bending strength for over 8 tons per meter square
5. Coarse surface makes organisms be easily attached.
6. Network shape and permeability are effective high-potent bio-filter materials without blocking.
7. Long life.
8. Low maintenance fees.
9. Arbitrary model (for example, floating, filtration, immersion) with arbitrary length.

種類和規格

型式 Model	有效表面積(m^2/m^3) Effective Surface Area	流通率(%) Flow Rate	孔隙率(%) Leaking Rate	管徑(m/m) Diameter of Pipes	單位處理量 Unit Amount
SAME-66	155 m^2/m^3	95%	92%	70mm	1~3kg/D

適用範圍

1. 養殖業循環水系統、工業污水、醫院污水、及生活污水、空氣污染防治。
2. 空氣污染防治：餐廳除油、除水霧（冷卻塔）。

APPLICATIONS:

1. Water circulation system for aquaculture, industrial sewage, hospital sewage, daily living sewage and water tower filler.
2. Air pollution prevention: Absorb oil smoke of restaurant, absorb water smoke of cooling water tower.

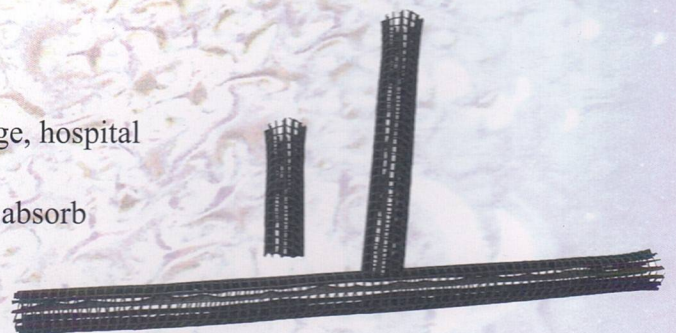



相同企業有限公司

SIMILAR ENTERPRISE CO.,LTD

高性能接觸濾材 PVC、ABS材質
Waved Crisscross Contact Filter

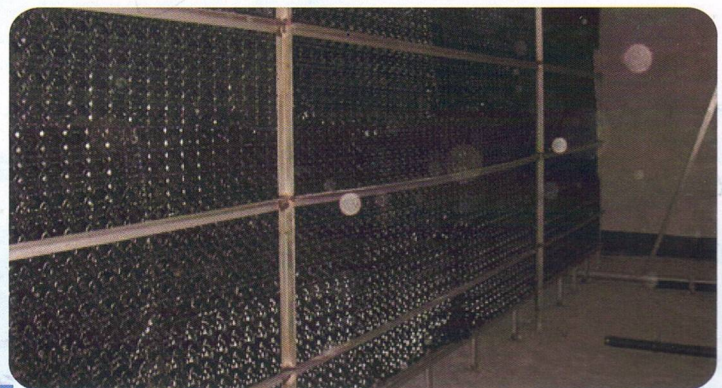
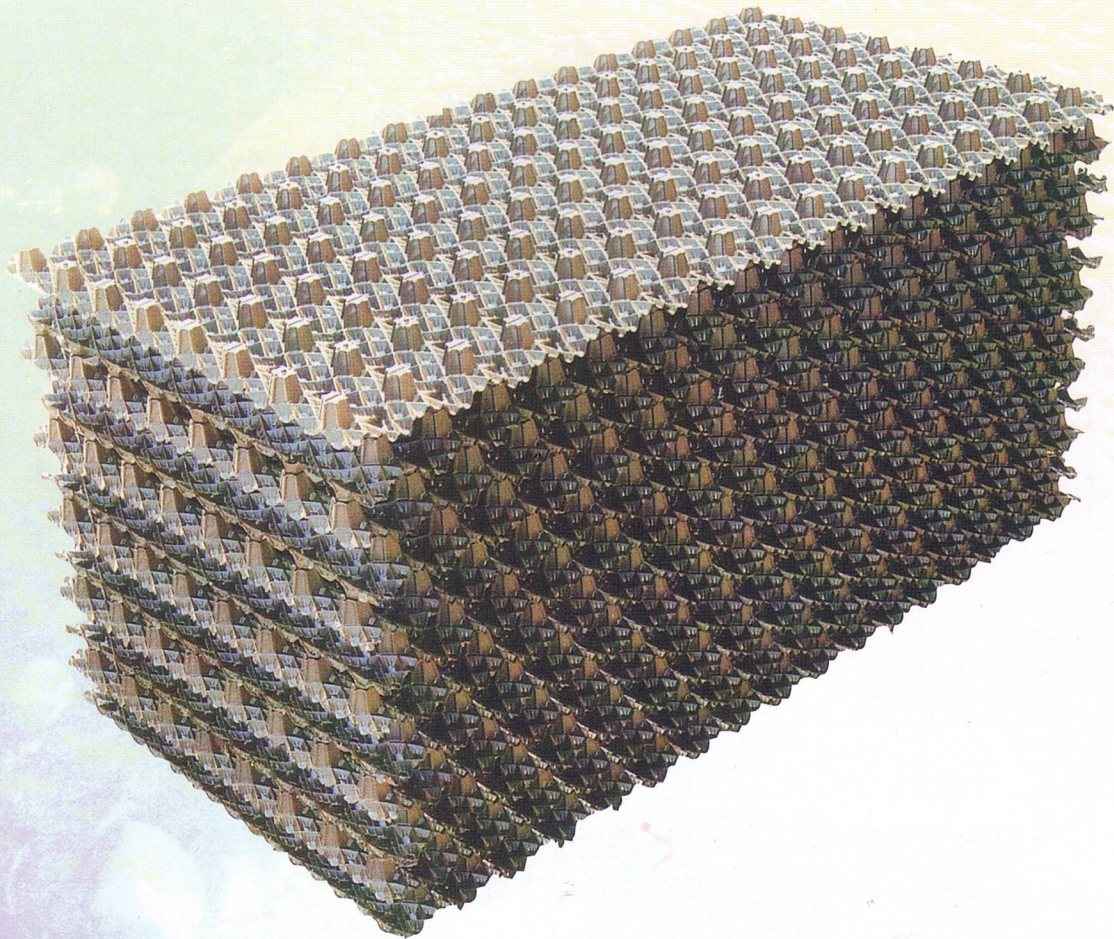

工程實例 sample

特性及優點

本接觸濾材由硬質波浪形塑膠板黏結而成，其整齊規律的縱橫交叉節點，在濾床內部一次次促使空氣及廢水在比鄰的節點間分佈、混合，促成有機與生物間不斷的接觸分解，產生了良好的生物處理效果。

濾材之結構設計呈凹凸狀表面，提供巨量的表面積，表面經特殊處理，精糙度適於微生物附著生長與剝落性，及盡可能開放空間，阻力小的結構體，以供空氣、水及懸浮固體物的流通，同時因考慮濾床內部生物膜之水力荷重，其構造在每片濾料厚度為0.4mm以上組合成一單體時，所能承受之壓力強度，經財團法人-金屬工業研究發展中心測試，抗壓強度達1500kgf/m²以上，因此無垮床之虞，實為費用低、效率高、具經濟效益之劃時代產品。

Features and Benefits

The contact filter consisted of the bonding hard wavy plastic plates. The neat crisscross nodes assisted the air and waste water distributing and mixing between neighboring nodes in the filter bed, then contributed to constant contact and decomposition of the organic matter and microbes to result a good biological treatment.

The structural design of this filter was concave-convex surface, providing a huge amount of surface area. The fine and rough degree of specially treated surface was suitable for microbial attachment, growth and flaking, also the structure of maximize space and low resistance was available for the circulation of air, water and suspended solids. Considering the hydraulic load of bio-film within the filter bed, each filter thickness of this structure was 0.4mm more to combine into a monomer. The compressive strength that tested by the Metal Industries Research & Development Centre was more than 1500kgf/m², so there is no danger of collapse base. It is really an epoch-making product in low cost, high efficiency, and with economic benefits.

運用實績

Instance of application

台南科學園區污水處理廠第二期工程

Sewage Treatment Works Phase 2 for the Southern Taiwan Science Park

台南大新營工業區、彰化基督教醫院、新竹醫院

Tainan Ta-Hsin-Ying ESTP, Changhua Christian Hospital, NTUH Hsin-Chu Branch,

台灣基督長老教會新樓醫院、台北海洋館.....等

Sin-Lau Hospital of the Presbyterian Church in Taiwan, Taipei Sea World.....etc.

規格尺寸

SPECIFICATIONS:

規格 Specification 型式 Model	間隙(m/m)	比表面積(m ² /m ³)	空隙率(%)	單片厚度(m/m)	標準尺寸 Standard dimension (m/m)		
	Aperture	Effective Surface Area	Leaking rate	Thickness of single slice	長L	寬W	高H
HCM-1200	45	120	99以上	0.4~0.6	1200	600	600



相同企業有限公司

SIMILAR ENTERPRISE CO.,LTD



八角型污水陰井 plastic sewage well

適用範圍

污水下水道系統、電信電力之手孔、社區生活污水管線連接、屋角集水陰井

APPLICATIONS:

Sewage line system, Hand of Telecommunications and Electricity, Community sewage pipe connection, fastigium catchment well.

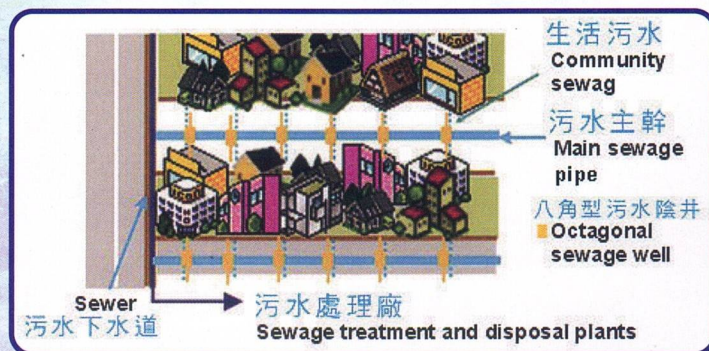

特性和優點



1. 採複合工程塑膠，強度佳。經國立中興大學土木工程系測試抗壓，可承受39噸正壓之高抗壓能力。
2. 八角型設計各面均有4"Ø 及8"Ø承口接管，使本體四面八方均能垂直連接進水管，使接管不需彎曲加工。
3. 接管承口配以 EPDM止洩橡膠確保陰井之密封，克服習用預鑄混凝土陰井易滲漏污染環境安全之環保問題，有避震及防止輕微之位移漏水現象。
4. 因材質為工程塑膠且為組合式，故重量輕，組裝搬運及施工相當簡便不需使用吊車，施工亦不受狹窄防火巷之限制，能有效節省施工時間及成本。
5. 本體採sus304不銹鋼螺絲連結耐久性高。
6. 為塑膠，故本體不導電。

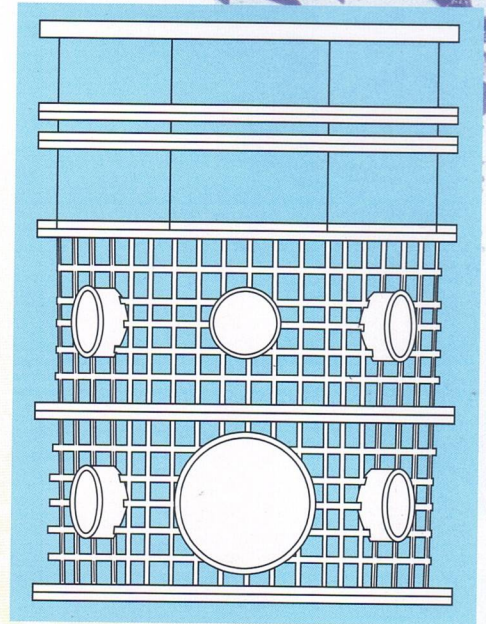

FEATURES:



1. With great strength by the material of construction plastic. Its resistance to pressure is tested to reach 39 tons by the Department of Civil Engineering of the National Chung Hsing University.
2. The octagonal design has 4" and 8" bearings on all its sides so that the housing can vertically be connected to the water pipes on all of its sides and the connecting pipes do not need to bent or processed.
3. The bearing of the connecting pipes are equipped with EPDM ejection-proof plastics for the sealing of well and to prevent the habitual use of pre-cast concrete well from easily leaking and polluting the environment. There is the set-up for shockproof set-up and minute displacement prevention.
4. Materials are plastics and assembled so that they are light and easily transported and assembled. They are convenient and do not need any cranes. It is not subject to the restriction of narrow fireproof lane at the time of construction and can effectively save time and costs.
5. The housing uses SUS304 stainless steel screw with high durability.
6. It is made of plastics so that the housing is not conductive.

規格



內徑600mm (組合成型且可隨意加高)

SPECIFICATIONS:

Diameter 600mm (Assembled and height increased at your will)

單位：mm

頂層 Cover of Frame	調節層 Adjustable layer	調節層 Adjustable layer	4"Ø	4"/8"Ø	8"Ø底座 Base
150	150	20.30.50	300	300	300

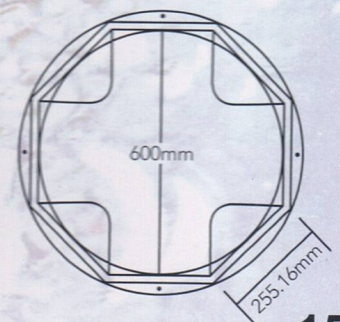



相同企業有限公司

SIMILAR ENTERPRISE CO.,LTD

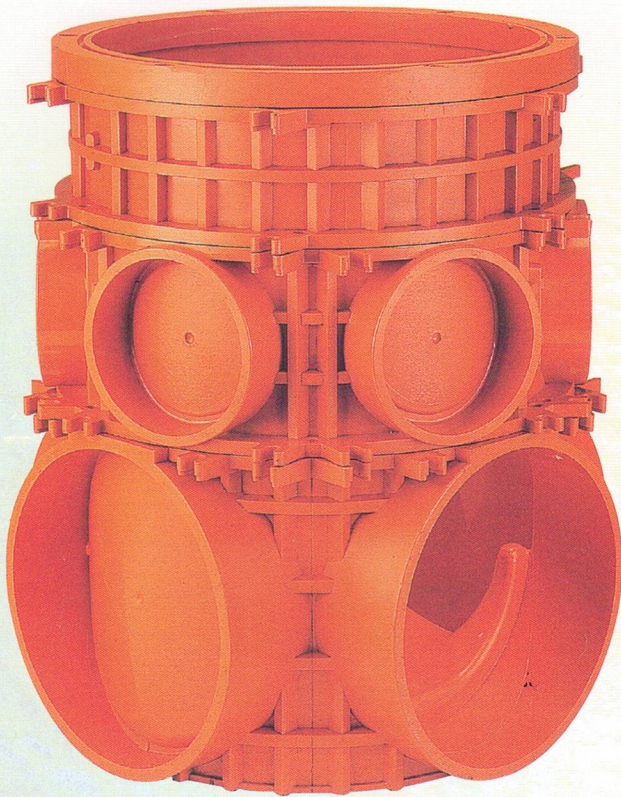

家庭污水配管箱
Kitchen Sewage Piping Box

適用範圍

污水下水道系統、電信電力之手孔、社區生活污水管線連接、屋角集水陰井

APPLICATIONS:

Sewage line system, Hand of Telecommunications and Electricity, Community sewage pipe connection, fastigium catchment well.

【多功能接管大小頭】

Multifunction connect hole



特性和優點

1. 採複合工程塑膠，強度佳，可承受12噸以上正壓之高抗壓能力。
2. 圓型設計角度可配合管線方向調整，且各面均有4"Ø及8"Ø承口接管，使本體各方均能垂直連接進水管而不需彎曲加工。
3. 接管承口配以自來水級止洩橡膠，確保配管箱之密封，克服習用預鑄混凝土易滲漏污染環境安全之環保問題，有避震及防止輕微之位移漏水現象。
4. 因材質為工程塑膠且為組合式，故可配合工程需要調整高度，而且重量輕，組裝搬運及施工相當簡便不需使用吊車，施工亦不受狹窄防火巷之限制，能有效節省施工時間及成本。
5. 本體採SUS304不鏽鋼螺絲連結耐久性高。
6. 材質為塑膠，故本體不導電。

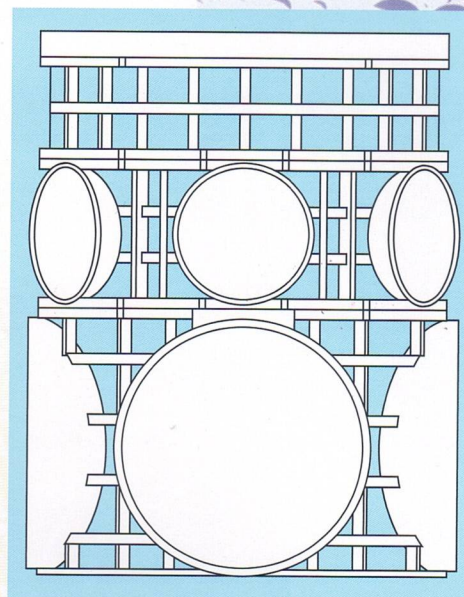

FEATURES:

1. With great strength by the material of construction plastic. Its resistance to pressure is tested up to reach 12 tons.
2. The design has 4" and 8" bearings on all its sides so that the housing can vertically be connected to the water pipes on all of its sides and the connecting pipes do not need to be bent or processed.
3. The bearing of the connecting pipes are equipped with water-proof rubber for the sealing of piping box and to prevent the habitual use of pre-cast concrete well from easily leaking and polluting the environment. There is the set-up for shockproof set-up and minute displacement prevention.
4. Materials are plastics and assembled so that they are light and easily transported and assembled. They are convenient and do not need any cranes. It is not subject to the restriction of narrow fireproof lane at the time of construction and can effectively save time and costs.
5. The housing uses SUS304 stainless steel screw with high durability.
6. It is made of plastics so that the housing is not conductive.

規格

內徑345m/m (組合成型且可隨意加高)

SPECIFICATIONS:

Diameter 345m/m (Assembled and height increased at your will)

單位：mm

墊層 Ceiling layer	墊層 Ceiling layer	墊層 Ceiling layer	Ø100mm 6孔中間層 Six holes middle layer	Ø200mm 4孔底層 Four holes base
25	100	300	150	255

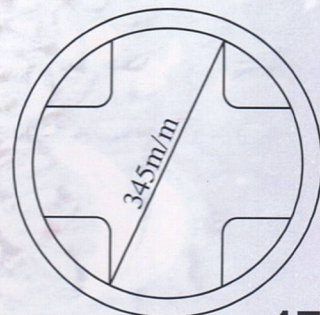



相同企業有限公司

SIMILAR ENTERPRISE CO.,LTD

生物旋轉盤 (RBC)

ROTATING BIOLOGICAL CONTACTOR



榮獲 97 年度優良國產環保設備品質評鑑證明

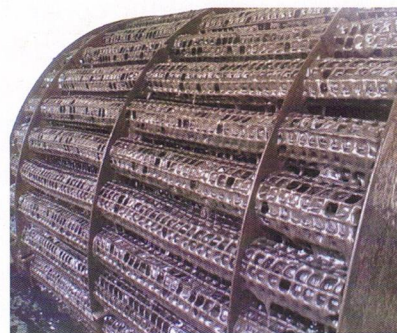
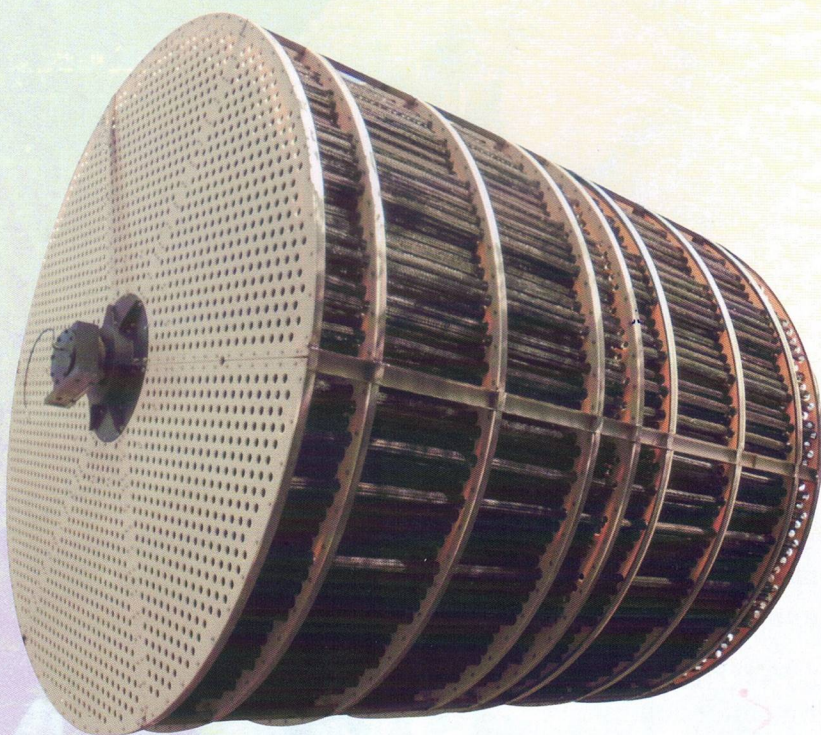

適用範圍：

生物膜處理法是處理廢水的新技術，此法包括水利技術，生物循環薄膜技術及微生物分離技術，對於含有高量BOD氮化物和碳化物之家庭、住宅及工業上的污水處理最為有效，同時亦最為經濟。

APPLICATIONS:

Bio-membrane treatment is a new technique for disposal sewage treatment. The technique includes water conservancy technique, bio-membrane circulation technique and microbe's segregation technique. It is most efficient and economic in dealing with residence and industry disposal sewage with high BOD nitride and carbide.

特性和優點：

1. 具有高度彈性：一般綜合污染廢水之水性、水量，皆複雜而變化大，在此一情形下污水處理的設置應極具高度彈性，以適合目前的需要及配合將來的擴展及變化。
2. 佔地面積少：在各種處理方法中，以使用生物膜方法佔地最少。
3. 節省電力：因轉盤速度低（2 rpm），故用電量極少與活性污泥法相較只有其耗電量的1/5或以下。
4. 維護簡易：在生物膜法中幾乎不需維護費，僅需轉動軸之定期潤滑。
5. 操作技術簡單：普通技工經訓練後即可操縱自如。
6. 對負荷量變動彈性大：對有機震動負荷與毒物外溢之抗拒力都較其他傳統方法為優，因廢水停留時間短所以對意外的毒性溢洩可以迅速地恢復。
7. 污泥量少濃度較高易處理，且無臭味及噪音。
8. 效率高：即無初級設備，具去除BOD5仍可90-98%。
9. 恢復迅速：在操作開始或停止操作後，恢復正常時間僅需3~5天。

FEATURES:

1. High flexibility: In general, the water feature and water quantity are complicated with big changes. Under this circumstance, the sewage treatment facilities should obtain high flexibility so to meet the current need and the future expansion and changes.
2. Small measure of area: Among all kinds of treatments bio-membrane treatment takes the smallest measure of area.
3. Low electricity consumption: Since the rotating contactor runs in low speed (2rpm), it takes very low electricity consumption. comparing with mud treatment, it takes only one-fifth of its electricity consumption or even lower.
4. Easy to maintain. It requires very little maintain fee except lubricating the rotating shaft periodically.
5. Easy to be operated. Ordinary workers with basic training can operate it smoothly.
6. Great loading flexibility: It is superior to other traditional treatments in organic vibrating loading and in resisting the overflowing toxicant. It is because the short stay period for disposal sewage, so the overflowing toxicant that happens accidentally can be recovered very quickly.
7. Small mud quantity with high concentration, no stinky smell either noise.
8. High efficiency: Even with no initial facilities, it can remove 90% to 98% of BOD5.
9. Fast to get reinstated: It takes only 3 to 5 days to get reinstated when operation starts or stops.

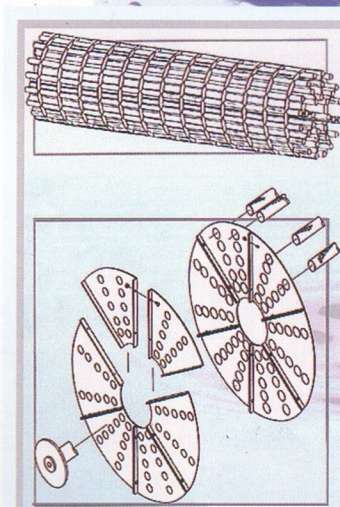

生物旋轉盤規格：

旋轉生物膜盤法是包括一系列平行的網葉狀圓形膜，所接連而成的生物膜盤組是垂直狀，約一半浸在廢液中另一半露於空氣中；生物膜盤組交換地旋轉於水及空氣中，由水中有機物所培養出來的微生物可以附著在旋轉盤面上而形成一所謂的生物膜，當生物膜和廢水接觸時可以分解或消化其中之好氧物，當曝露於空氣中時可繼續獲得好氧菌類所賴以維生的氧氣，如此不斷的循環反應可使廢水中的污染性或好氧物逐漸減少而達到排放準。

SPECIFICATIONS:

The rotating biological contactor (RBC) contains a serial of parallel network round shape filter that vertically joined. Half part of it is immersed in disposal sewage and half part of it is explored in air. The RBC interlock revolves around in water and in the air. Microbes that cultivated from organisms in water then adhere to RBC and form the bio-membrane. When the bio-membrane contact the disposal sewage it decomposes of digests the oxygen-fond microbes, and when it explodes in the air it continuously gains the oxygen, which required by oxygen-fond gem. With this rotating reflection the polluting condition and the oxygen-fond microbes will be reduced and reach to the discharge standard.

NAME/MODE 名稱/型式	SAME-30
表面積 Surface square measurement	2350m ²
盤體 RBC housing	網葉狀 Network shape
圓盤直徑 Panel diameter	3000mm(尺寸可依需求訂製) 3000mm(size as per request)
生物膜材質 Bio-membrane material	HDPE
中心主軸 Central shaft	無縫鋼管 Seamless stainless steel tube
轉速 Running speed	主軸轉速為每分鐘 2 轉 週邊速度為每分鐘 18.85m The main shaft rotates two times per minutes while the side speed is 18.85m per minute.
馬達 Motor	2HP
減速機 Retarding machine	CYCLO 二段式或 HELICAL Two sections of CYCLO or HELICAL
軸承 Bearing	型式自動調正滾子軸承 Automatically change the bearing
防蝕處理 Etch prevention treatment	鋼材部分佈環氧樹脂(SUS304 除外) The steel contains oxygen-encircled resin(except SUS304)



相同企業有限公司

SIMILAR ENTERPRISE CO.,LTD

高傳氧散氣盤

High Oxygen Transfer Disc Diffuser

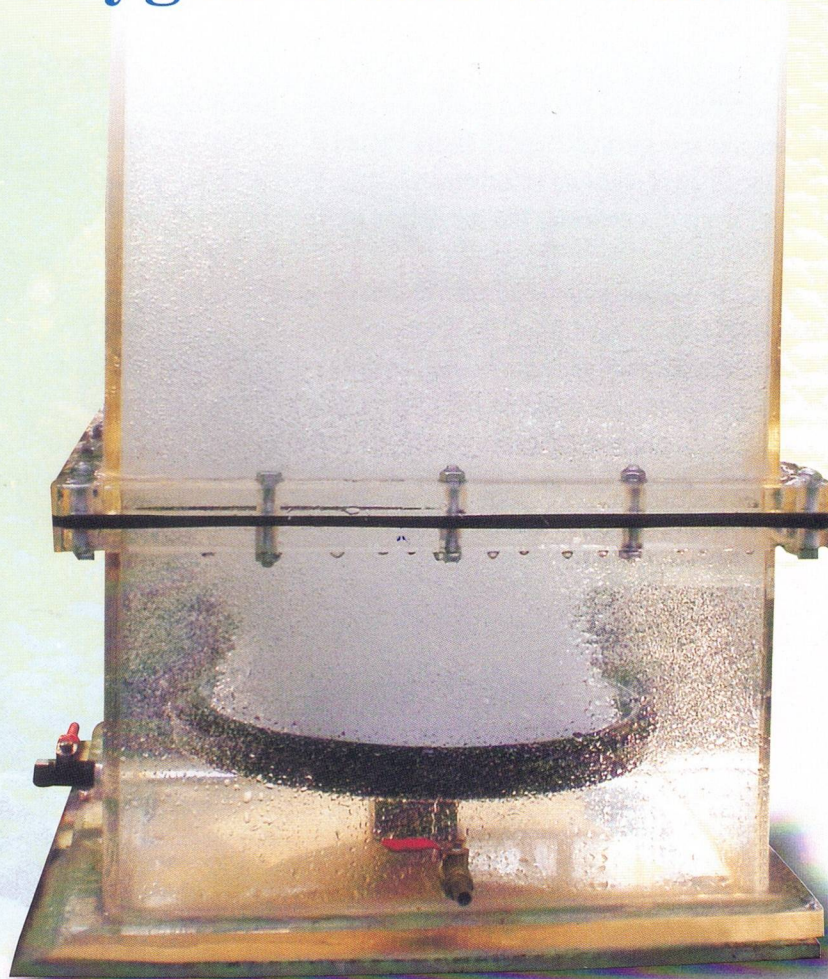

傳氧效率表

Table of oxygen transfer efficiency rate (OTE)

工業技術研究院
Industrial Technology
Research Institute

規格 Model/Specification	材質 Material
直徑 Diameter Ø300mm	基座 Seat ABS
接頭 Connector Ø3/4" NPT	透氣膜 Air membrane a high polymer(高分子)
曝氣量 Aeration volume 0.01~0.10m ³ /min	拉力 Tension strength >10kgf/25cm
逆止膜材 Non-return valve EPDM	伸長率 Elongation rate <20%
	基重 Basic weight 170±15g/m ²
	厚度 Thickness 0.85±0.05mm

種類 (-)	風量 (Lpm)	KLa20值 (1/h)	傳氧效率(SORT) (%)	備考
相同散氣盤 SAME Disc Diffuser	60	35.1	18.3	18.3~25.4 *60~30Lpm
	50	32.8	20.4	
	40	29.8	23.2	
	30	24.4	25.4	
	20	17.2	26.9	
市售散氣盤 Ordinary market disc diffusers	60	33.5	17.4	17.4~21.8 *60~30Lpm
	30	21.0	21.8	

主要性能及結構

本設備採用低阻抗材質，膜面為高分子長纖不親水性經特殊光滑處理，具有6000個/cm²以上之透氣孔設計，通氣後呈放射狀細氣泡，其風壓損失小於200mmAq(水柱)。在散氣膜片與通氣口間還設有一逆止閥，該逆止閥具有一可對應倒錐形柱體，及一可向上頂撐開散氣膜片，向下封密通氣孔之閥瓣。因其透氣膜為高分子長纖結合其表面抗張強度經測試為10kg/25mm以上，並具20%以下之低延伸率，更適合使用於深度較深之曝氣功能。

Main functions & structure

Made up of low resistance materials, the device has a membrane surface composed of high polymer, hydrophobic long fibers. The specially gloss-treated surface is designed with more than 6000/cm² pores to generate radiating fine air bubbles with less than 200mmAq (Aqua) wind pressure.

The check valve located at the diffuse membrane and the air opening is installed with a corresponding inverted cone, an upward diffuse membrane, and a downward sealed air valve.

The high polymer long fibers, combining with tensile resistance strength of more than 10kg/25mm, and an elongation rate of less than 20%, make our diffuser more suitable for aeration function in deeper water.

產品特點

高強度、耐高溫(150°C)性能好(可在90°C環境中長期使用)、耐老化、抗紫外線、穩定性和輕質、透氣性好、耐腐蝕、耐酸，鹼性強，風壓損失低。

Features

High strength, high thermal resistance of up to 150°C, good functionality (long durability under environment of 90°C), aging resistant, anti-ultraviolet rays, high stability and light-weight, super ventilation, anti-erosion, anti-acid, strong basicity, and low wind pressure loss.

高傳氧效率

當空氣通過散氣盤時，超過6000個/ft²細小孔隙均勻的分布在散氣盤膜片上，並且不斷地產生0.5~3mm粒徑之細小氣泡，大大地增加空氣與水接觸面積，經工研院能環所實際檢測能有效地提高空氣在水中傳氧效率到達26%以上。

High oxygen transfer efficiency

When air passing through more than 6000/cm² pores distributed evenly across the membrane of the disc diffuser, it continuously generates fine bubbles with a grain diameter of 0.5 ~ 3mm, which can increase air-water contact area to a great extent. SAME Disc Diffuser has been scientifically proven to have an oxygen transfer rate of over 26% by the Energy and Environment Research Laboratories of Industrial Technology Research Institute.

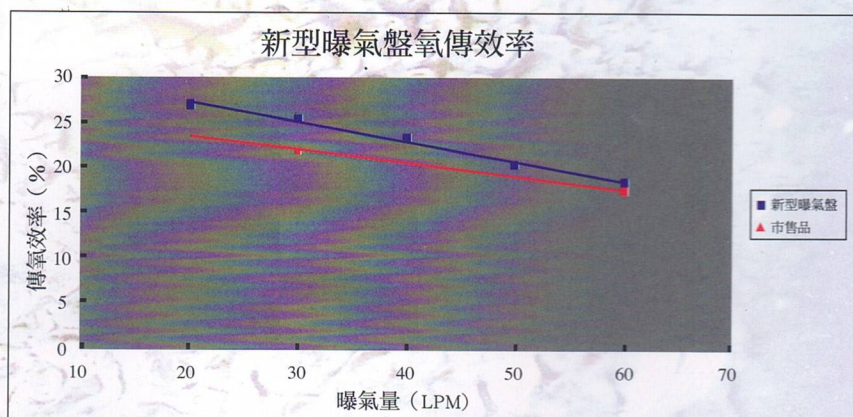
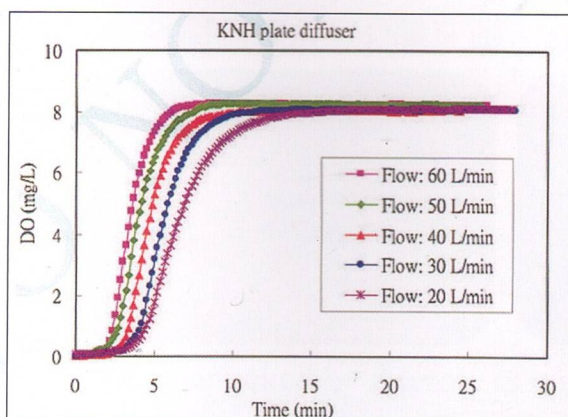



相同企業有限公司

SIMILAR ENTERPRISE CO.,LTD

噴射渦流式粗氣泡散氣盤

ENVIRONMENTAL PROTECTION

DIFFUSER

組裝示意圖

Assembly diagrams

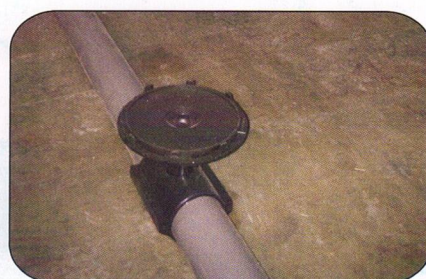
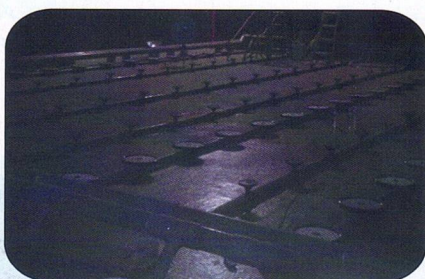
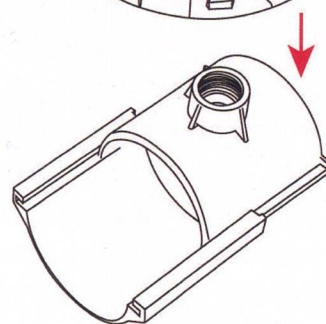
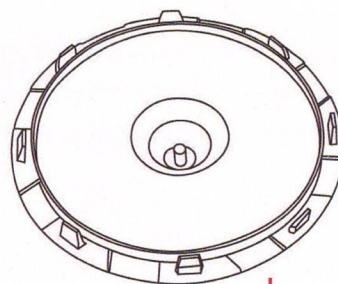
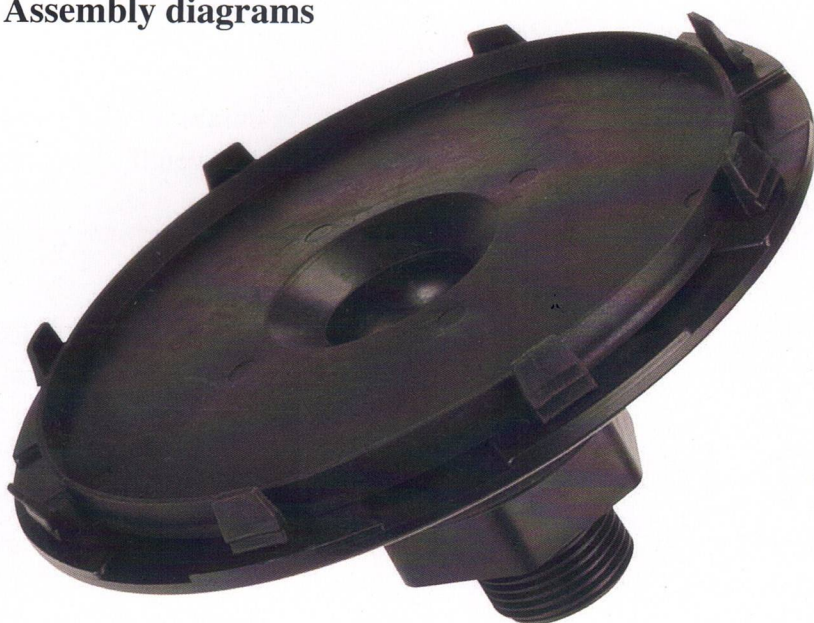

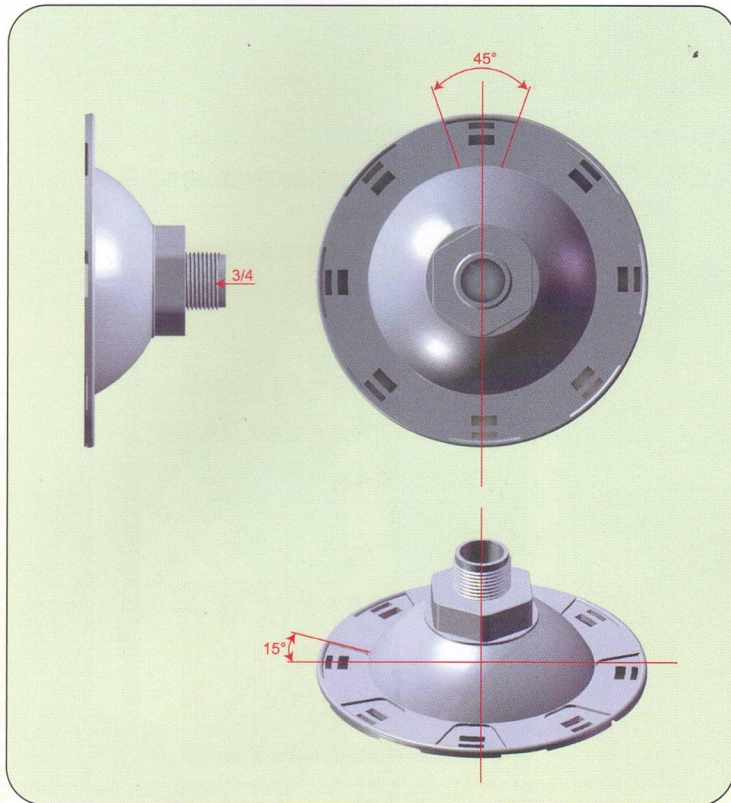

規格

- A. 3/4"牙口
- B. 直徑：144m/m
- C. 通氣量：100~450ℓ/min

構造材質

擴散蓋TPR：Neoprene Rubber耐酸鹼
擴散基座：ABS

特點

1. 配合國內現成3/4"龍牙頭，或鞍座安裝容易
2. 噴射出風口45°導流，形成渦流停留時間久，溶氧效率高
3. 有逆止作用，永不阻塞

Feature

1. Easy to install with off-the-shelf 3/4 " thread head or saddle.
2. Jet outlet with 45° diversion to form a vortex, remaining long time for high efficiency of dissolved oxygen.
3. Never blocked by the role of backstop.

Specification

- A. 3/4" screw thread
- B. Diameter: 144m/m
- C. Aeration amount: 100~450ℓ/min

Material of Structure

Diffusion Cover TPR: Neoprene Rubber -
Acid and alkaline resistance.
Diffusion Base: ABS

榮譽專利證書

About Our Company

台灣區環保設備工業同業公會
(102)台發公會證字第 093 號

會員證書

相同企業有限公司 業經依法
加入本會為會員 此證
計開
負責人姓名：賴錫隆
地址：台中市烏日區溪南路一段 506 巷 485 號
資本額：新台幣捌佰伍拾萬元整
會員等級：乙級

備註：
(一) 證類比價以本證書為準，不另發比價證明書
(二) 本證書有效期間至 102 年 12 月 31 日止逾期作廢

理事長 朱俊彥

中華民國一〇二年一月

優良國產環保設備品質評鑑證明

相同企業有限公司之「生物旋轉盤」
，通過本局97年度優良國產環保設備
品質評鑑，特此證明。

經濟部工業局局長

中華民國 97 年 11 月

環保設備品質認證證書
Environment Protection Equipment Quality Certificate

證書編號：0033
Certificate No. 0033

茲證明
This is to certify that

相同企業有限公司
Similar Enterprise Co., Ltd.

明渠狀生物接觸濾材 SAME-66/生物膜接觸濾材 HCM-60/
蜂巢式生物接觸濾材 HCM-CM 系列 / 傾斜管 HCA 系列
Web Tubular Bio-Contact Media-SAME 66 / Bio-Film
Contact Media-HCM 60 / Honeycomb Organism Contact
Material-HCM, CM Series / Tube Settler-HCA Series

經本公會國產環保設備品質評鑑委員會認證審核通過
Tainwan Environmental Manufacturers Association

台灣區環保設備工業同業公會
Chairman Chen-Rong Chian

江政榮
中華民國八十九年十一月六日
November 6, 2000

優良國產環保設備品質評鑑證明

相同企業有限公司之「 $\phi 345$ m/m 塑膠
圓形配管箱 HCO- $\phi 345$ 」，通過本局九
十三年度優良國產環保設備品質評
鑑，特此證明。

經濟部
工業局局長 陳昭義

中華民國九十三年十一月十九日

優良國產環保設備品質評鑑證明

相同企業有限公司之「 $\phi 600$ m/m 塑膠
八角型污水陰井 HC8- $\phi 600$ 」，通過本局
九十三年度優良國產環保設備品質評
鑑，特此證明。

經濟部
工業局局長 陳昭義

中華民國九十三年十一月十九日

榮譽專利證書

About Our Company

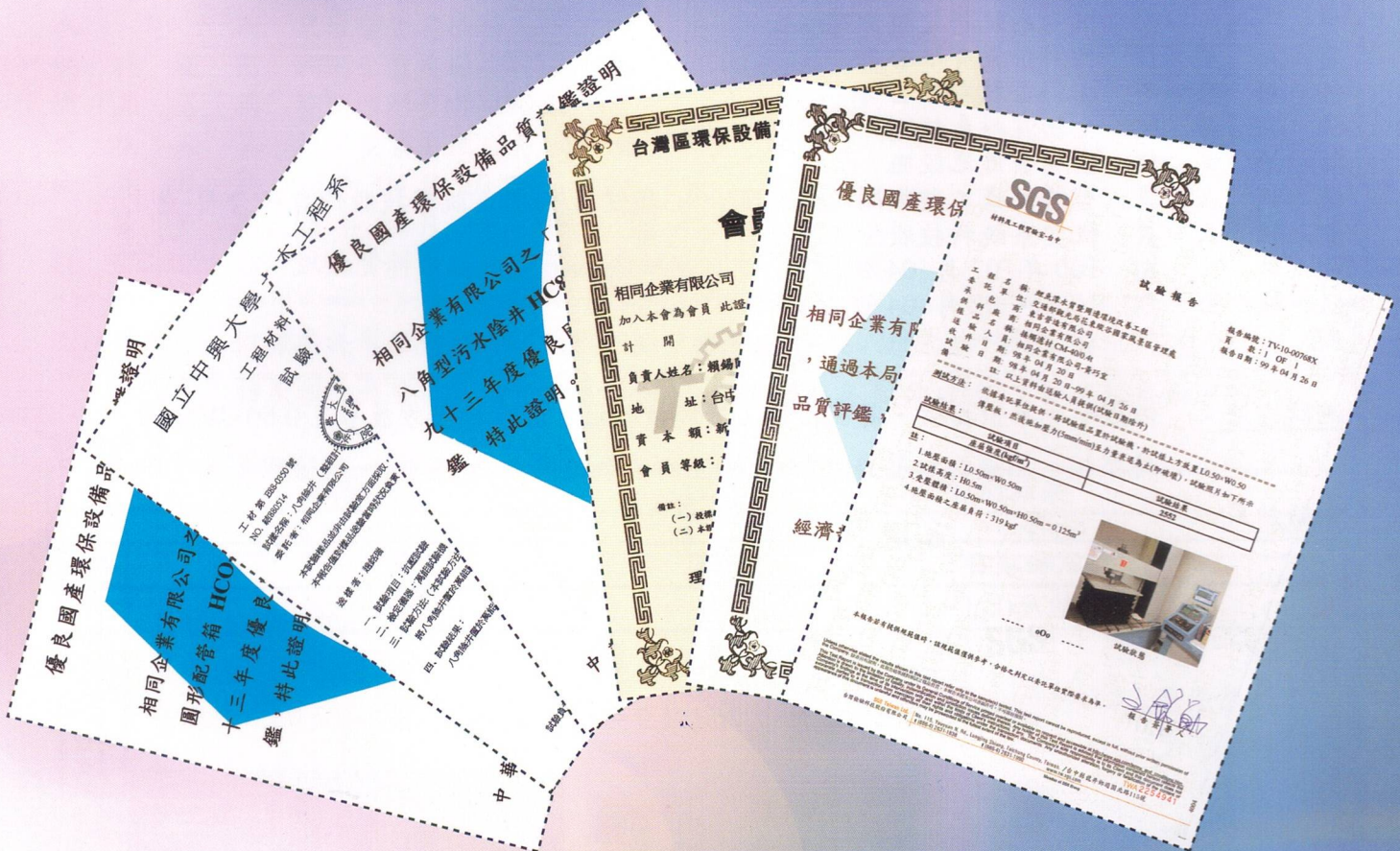

國立中興大學土木工程系

工程材料試驗室

試驗報告

共一頁 第一頁

中華民國 88 年 05 月 31 日

試驗日期：88.05.31

工材第 E88-0350 號

NO. 結880514

試樣名稱：八角陰井（整組計六件）

委託者：相同企業有限公司

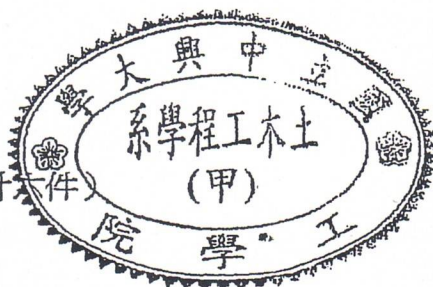

本試驗樣品並非由試驗室方面採取，故所列紀錄僅對樣品本身負責。

本報告僅對樣品送驗當時狀況負責。

送樣者：趙銘瑞

- 一、試驗項目：抗壓試驗
- 二、檢定儀器：萬能試驗機
- 三、試驗方法：（本試驗方法由委託者提供如下）

將八角陰井置於萬能試驗機上施加軸向荷重至破壞。

四、試驗結果：

八角陰井置於萬能試驗機上施加载重至39000 kgf 時開始大變形，承載能力下降。



試驗負責人



試驗者

